

## AUTOMATIC TARGETING SYSTEM

DHRUV MEHTA<sup>1</sup>, HARSH KOTAK<sup>2</sup>, GRISHMA VITHALANI<sup>3</sup> & PRITHVISH MAMTORA<sup>4</sup>

<sup>1,2,4</sup>B. E (EXTC.), D. J Sanghvi College of Engineering, Mumbai, Maharashtra, India

<sup>3</sup>B. E (Biomed.), D. J Sanghvi College of Engineering, Mumbai, Maharashtra, India

### ABSTRACT

Currently our borders are protected by Iron Spike fences, and a watchtower containing soldiers continuously flashing the light over the border area day and night. Those persons are fully responsible to prevent any intrusion. This project will not fully remove the responsibility of the soldiers, but manages to take the maximum responsibility and thus reduce human mistakes on the border. The basic purpose of the project is to enhance the border security electronically with automation and with that to reduce the work load and responsibility of the border men that continuously take a look on border 24x7. Also, the project can be used on small scale in home security at night by simply adjusting the range of the project.

**KEYWORDS:** PIR Sensors, AT89C51 Microcontroller, FSK Transmitter and Receiver

### INTRODUCTION

Passive IR Sensor Based Automatic targeting System for Border Area is an automated gun target and firing system. The project is primarily based on PIR Sensors, Microcontroller and wireless transmitting and receiving units using FSK. The sensors will sense any living object inside its range and provide the signal to microcontroller. Using this signal, microcontroller generates the code on the site and transmits to the watch tower. The receiver receives the code, microcontroller decodes it, interprets the location of the object corresponding to received code, which activates the targeting system [2]. The gun (in this case, a toy laser) is mounted on the motor. The sensor detects the intruder, sends the signal to microcontroller which then executes certain code and signals the motor to rotate so as to point the gun to the intruder. It then activates the buzzer alarm and firing control.

### SYSTEM ARCHITECTURE

The PIR Sensor senses the motion of a human body by the change in surrounding ambient temperature when a human body passes across it. The output of the sensor is given to different ports of microcontroller. The microcontroller in turn gives output which acts as in input to encoder. The encoder converts parallel input (output of microcontroller) into serial output. This serial output is given to 434MHz FSK transmitter which in turn transmits the data [3].

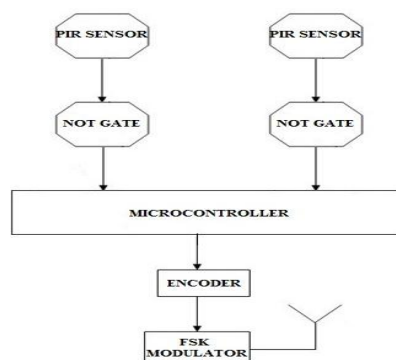

Figure 1: Block Diagram of the Transmitter Section

The FSK receiver receives the serial output of encoder. It gives this output to decoder which converts the serial output to parallel output. This parallel output is given to different ports of microcontroller. The microcontroller treats the data at different ports as input and executes the code to give output at the selected output ports where buzzer, laser and h-bridge driver circuit is connected.

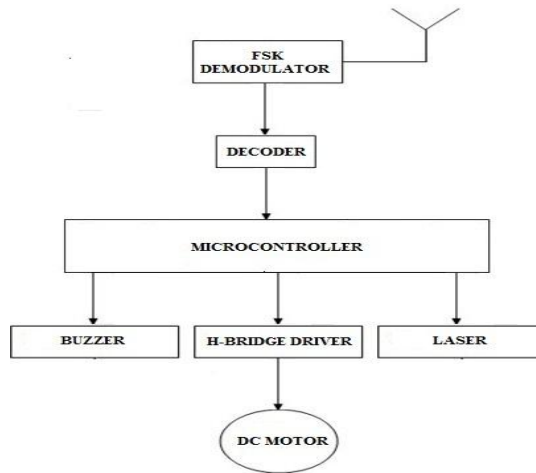

Figure 2: Block Diagram of the Receiver Section

**SYSTEM WORKING**

**Transmitter**

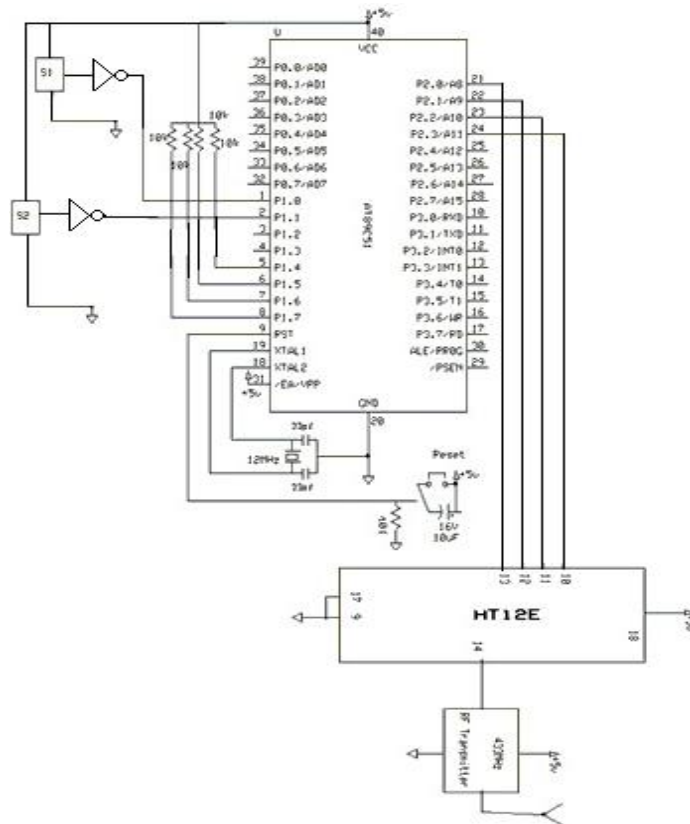

Figure 3: Circuit Diagram of the Transmitter Section

The circuit diagram consists of the Passive IR Sensors (S1,S2) that detects the invisible IR radiations of the any living object and generates a weak (small) signal which goes to the NOT gate. The NOT gate hereby, compliments the signal, makes it readable to the microcontroller and then microcontroller generates a code corresponding to the sensor detection.

As the code is generated which looks like something as 0000 0001, 0000 0010, etc is transmitted to the encoder by the microcontroller. This code is sent to the FSK Transmitter section for modulation of signal and transmission of signal wirelessly.

Each passive IR sensor generates the signal at different port of the microcontroller and it then depends on the microcontroller to generate a unique corresponding code related to the passive IR sensor detection [8].

**Receiver**

The receiver section consists of FSK receiver, Microcontroller, H- bridge function, decoder IC, DC motor, Firing Laser gun, and Buzzer Alarm. The signal received by the FSK receiver is demodulated by a demodulator and then the signal is decoded by a decoder IC. Then the signal is transmitted to the microcontroller and microcontroller retains the code transmitted by a transmitter and performs the function accordingly.

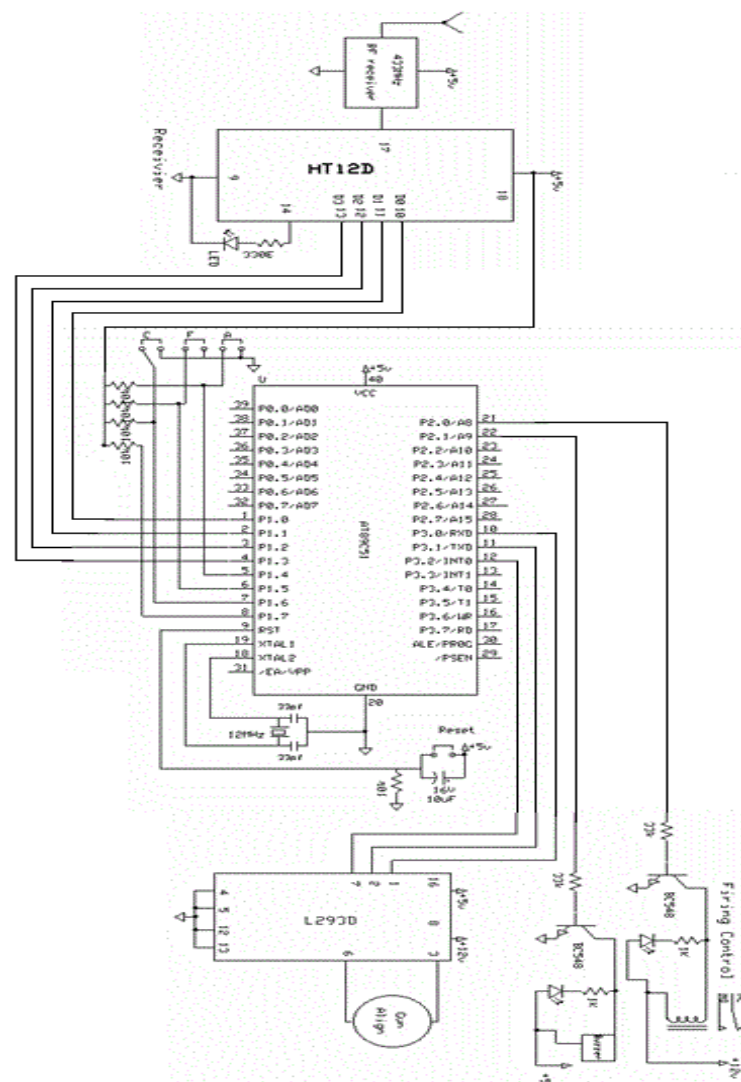

**Figure 4: Circuit Diagram of the Receiver Section**

The signal received and code regenerates is called obtained code. The format of the obtained code is the 10111111, 01111111, etc. Each code regenerated leads to some target function. The code will decide how much degree will the motor rotate and targets itself to the object location and the buzzer module activates that alerts everyone present.

After the buzzer system gets activated and laser gun starts firing over the target location. The laser fires until the sensor stops sensing the IR radiations. This leads to complete destruction of the living object near the border area. The

rotation can vary accordingly to the sensation of the sensors as the code transmitted will rapidly changes. The transmitter and receiver can be at within the range of FSK transceiver.

## ALGORITHM

The AT89C51 microcontrollers at the transmitter and receiver sections are programmed using Kiel uVision.

### Transmitter Algorithm

*Initialize → counters and reset ports*

*Define → variables and delay function*

*Initialize → port for serial communication*

*Data polling*

*Observe data received from sensor via NOT gate.*

*If P1 → 01111111*

*Then P2 → 1000000*

*Delay*

*Reset port 2*

*Else if*

*P1 → 10111111*

*Then P2 → 0100000*

*Delay*

*Reset port 2*

### Receiver Algorithm

*Initialize → counters and reset ports*

*Define → variables and delay function*

*Initialize → port for serial communication*

*Data polling*

*Observe data received from the decoder*

*If P1 → 01111111*

*Then P3 → 1100000*

*Delay*

*Reset port 3*

*P2 → 11000000*

```
Delay  
Reset port 2  
Else if  
P1 → 10111111  
Then P3 → 1010000  
Delay  
Reset port 3  
P2 → 11000000  
Delay  
Reset port 2
```

The data transmission is carried out in between a pair of identically designed transmitter-receiver antennas.

## RESULTS

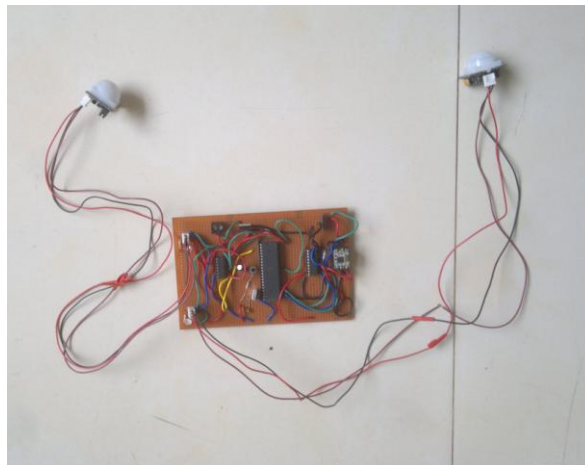

**Figure 5: Image of the Transmitter Section**

An archetype of the targeting system is installed as a home security system due to its limited areas of possible intrusion. The transmitter and sensing section is placed at the area of entry. The PIR sensors detect any human intrusion and is accordingly processed and transmitted to the receiver via the FSK transmitter.

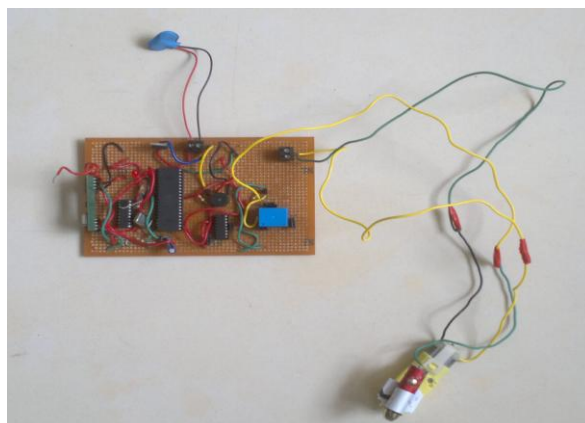

**Figure 6: Image of the Receiver Section**

The receiver is placed inside the house approximately 5 feet away from the transmitter. The receiver decodes the received data and accordingly rotates the motor to target the intruder while simultaneously ringing the buzzer alarm to alert other people.

## FUTURE SCOPE

Following few future enhancements can be implemented on this project to make the system more accurate.

- Instead of using Passive IR sensors, we can use Infrared Cameras that detect human heat more accurately.
- GPS can be used instead of FSK transceiver to find exact location of the object.
- Advanced microcontrollers could be used to reduce the processing time and thus improve efficiency.

## CONCLUSIONS

The idea of the Targeting system is implemented specifically for the border area, but can be modified and could be used in any of the security requirements on scaling of cost and complexity.

For the border area, PIR sensors can detect human intrusion accurately. The cost of the system depends on the application but is generally reasonable; range can be varied as per requirement by setting sensors. The accuracy of the project will significantly increase under manual assistance as the basic thinking of the project is taken by working with human but not alone taking responsibility of the complete security.

## REFERENCES

1. M. Hazas, J. Scott and J. Krumm "Location-aware computing comes of age", *IEEE Computer*, vol. 37, no. 2, pp.95 -97 2004
2. M. Moghavvemi and C. S. Lu "Pyroelectric infrared sensor for intruder detection", *Proceedings of TENCON 2004*, pp.656 -659 2004
3. S. Okuda , S. Kaneda and H. Haga "Human position/height detection using analog type pyroelectric sensors", *Lecture Notes in Computer Science*, vol. 3823, pp.306 -315 2005
4. MEMS for Distributed Wireless Sensor Network, Brett A., Kristofer S.J. Pister, Berkeley Sensor and Actuator Center, 9th IEEE International Conference on Electronics, Circuits, and System, September 16, 2002
5. N. Patwari, R. J. O'Dea, and Y. Wang, "Relative location in wireless networks," in *IEEE VTC*, vol. 2, May 2001, pp. 1149-1153
6. K. Lee, "Wireless sensing and IEEE 1451," presented at the Sensor Conf./Expo 2001, Chicago, IL.
7. D. H. Pollock, Ed., *The Infrared and Electro-Optical Systems Handbook*. Ann Arbor, MI: SPIE Opt. Eng. Press, 1993, vol 7
8. Muhamad Ali maizidi book Edition 2nd, 2010, Microcontroller & Embedded system.
9. Adrian Perrig, John Stankovic and David Wagner, "Security in Wireless Sensor Networks", *Communications of the ACM*, Vol. 47, No.5, pp. 53-57, June 24.